

# MagneTOF™: A New Class of Robust Sub-nanosecond TOF Detectors with Exceptional Dynamic Range

MagneTOF™ detectors provide an exceptional combination of performance characteristics. They eliminate the compromises associated with previous TOF detectors.

The high performance version, DM167, typically achieves pulse widths of 0.4 ns FWHM while the DM291, developed as a compact, lower cost version, achieves 1.0 ns pulse widths FWHM.

Special attention has been given to minimizing jitter so that pulses from multiple ion events have nearly the same width as single ion events.

The DM291 has a field replaceable amplifying section, which will restore an aged detector back to its as-new condition.

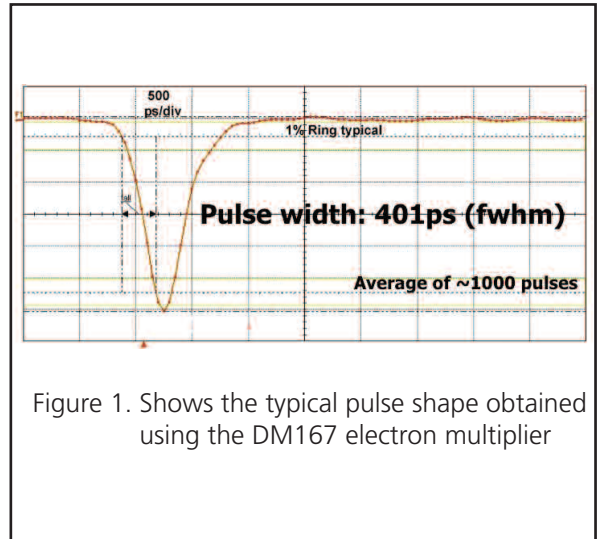

Figure 2. MagneTOF™ detector range: DM291 (left), DM167 (right), DM345 AC signal coupler (foreground).

ETP detectors have become the preferred detector for many TOF applications during the past 14 years because of their many advantages over the alternative MCP detector.

The MagneTOF™ series of TOF detectors include all the same high dynamic range and ease of use features of other ETP detectors but exhibit sub-nanosecond pulse widths.

The DM345 AC Signal Coupler is an accessory that can be used with either MagneTOF™ detector and provides 15kV isolation for the output signal. The DM345 has minimal influence on the MagneTOF™ detectors' pulse shapes.

### DM167 Electron Optics

The features are illustrated in Figure 3.

1. An outer grid, which can be fixed at a user defined voltage (within  $\pm 5$  kV of -HV), is included in the design for ease of integration into a TOF system.
2. The ion input grids are made from parallel wires stretched over a flat frame enabling precision control over transmission to 92%.
3. To take advantage of narrow pulse width it is important to minimize jitter and arrange for minimum disturbance to the input ions as they pass through the detector to the impact surface. To achieve this:
  - a. Careful attention has been paid to achieving a very uniform electrostatic field in the ion transit area. The small “kick-up” at the right end of the ion impact plate is an example of the design details included to achieve this goal.

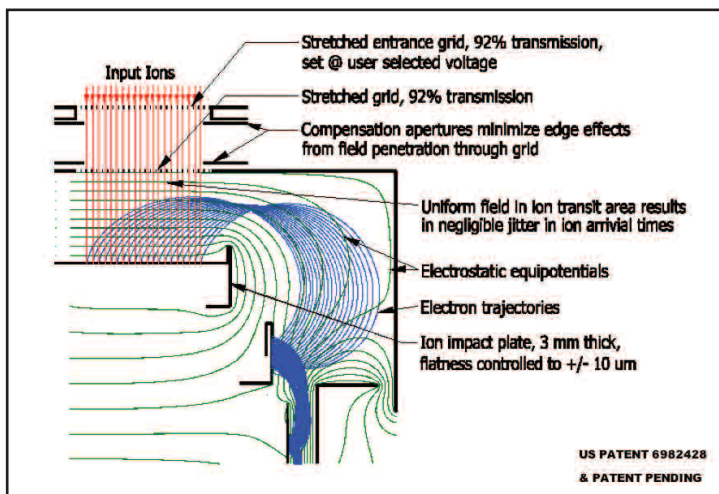

Figure 3. Shows the electron optics of the DM167 detector.

b. Each internal transmission grid is equipped with a compensation aperture which compensates for edge effects from field penetration through the grid.

c. The ion impact surface is made from 3 mm thick stainless steel (coated with appropriate dynode materials). This allows for an unusually flat ion impact surface:  $\pm 10 \mu\text{m}$  is standard,  $\pm 5 \mu\text{m}$  or less is optional.

d. The grids are made from parallel wires stretched over a flat frame enabling very flat grid surfaces.

Specifications	DM167	DM291
Multiple ion pulse width (FWHM) (ns)	<0.5	<1.0
Input aperture size (mm)	15 X 33	10 X 25
Mechanical envelope size (mm) <sup>1</sup>	44 X 52 X 96	38 X 40 X 60
Linear response:	During & after a burst of 300,000 ions	
Linear response:	>1 Volt output pulse (into 50 Ohms)	
Linear response:	10 $\mu\text{A}$ sustained output current	
Linear response:	For spatially concentrated ion beams	
Impact surface flatness:	$\pm 10 \mu\text{m}$ ( $\pm 5 \mu\text{m}$ or less optional)	
Maximum dark counts:	20 per minute @ 3000 Volts	
Recovery time after large pulse:	Negligible	
Maximum operating pressure:	$10^{-4}$ Torr	
Long/short term storage requirements:	Protect from dust	
Ion detection efficiency (low mass):	80%	
Conditioning time after pumpdown:	None	
Operating voltage <sup>2</sup> :	~2500 (initial) to 4000 (aged)	
Typical gain at 2500 volts:	$10^5 = \sim 1$ mV into 50 Ohms	

1. Mounting tabs protrude beyond each of these envelope sizes.
2. Up to 0.5 mA will be drawn from the HV power supply.

### Ion Burst Test: DM167

The ion burst test is a realistic measure of the performance one can expect from this detector during a very high abundance TOF spectrum.

The DM167 was exposed to 5 microsecond bursts of ions with a 1% duty cycle. The lower trace is the average of ~2500 ion bursts and hence indicates the average detector output current, and therefore instantaneous detector gain, during the burst.

The DM167's averaged output of 30 mV (or 600  $\mu\text{A}$  into 50 Ohms) during the 5 microsecond burst is the equivalent of an ion input rate of  $6 \times 10^{10}$  ions per second for 1 mV single-ion-pulses. This corresponds to a total of 300,000 ions during the burst. From the data it is apparent that this ion burst rate has negligible influence on the DM167's gain.

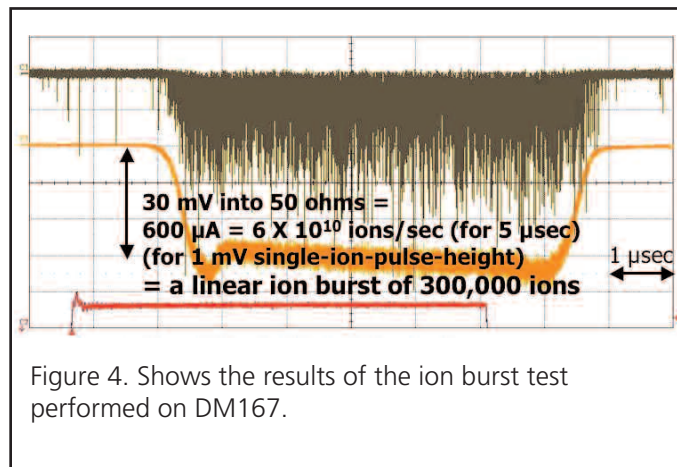

Figure 4. Shows the results of the ion burst test performed on DM167.

### Pulse Height Distribution

The typical pulse height distribution of a MagneTOF™ detector shows a number of small peaks spaced over the distribution. These are a result of the very high secondary electron yield from the 2nd dynode. This enables the resolution of the individual peaks resulting from the Poisson distribution of secondary electrons generated by ion impact on the 1st dynode.

The dark blue blocks show the Poisson distribution for a mean of 2.0 events. This is the expected distribution of the number of electrons emitted from an ion impact with an average yield of 2, which is appropriate for the 30 amu, 3 keV ions used to collect this data.

The distribution is dominated by the ion impact secondary yield characteristics and therefore is as narrow as can be expected from a non-saturating detector. A larger yield and thus narrower distribution can be expected from higher energy ions.

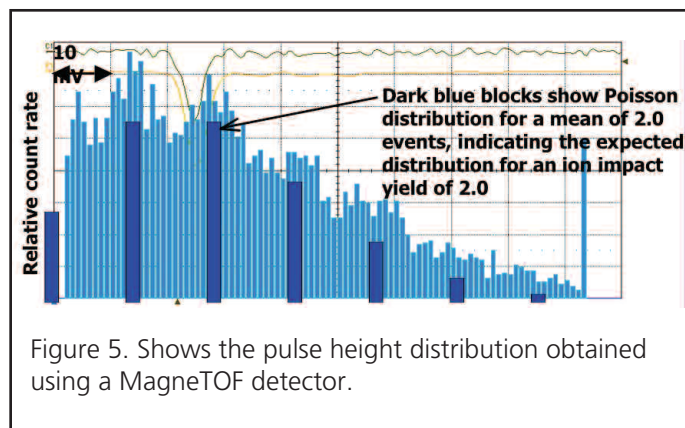

Figure 5. Shows the pulse height distribution obtained using a MagneTOF detector.

**US PATENT 6982428 & PATENT PENDING**

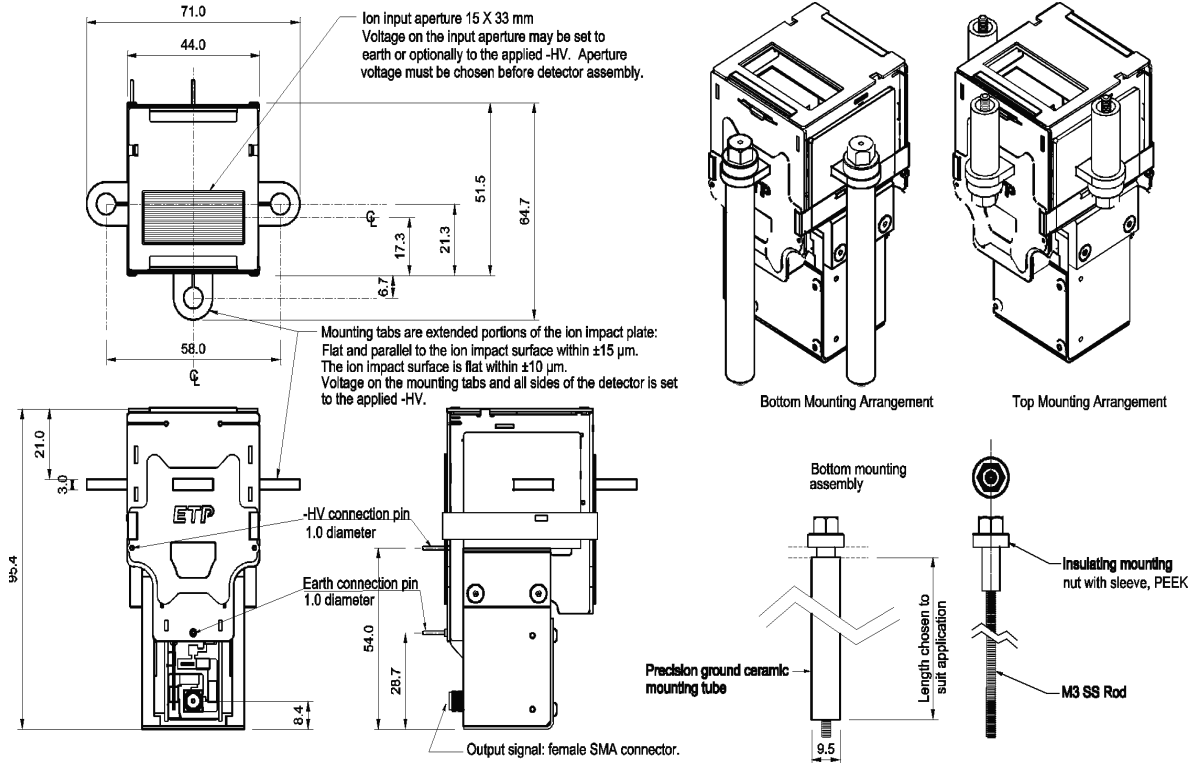

Figure 6. Shows the mechanical details for the DM167 electron multiplier.

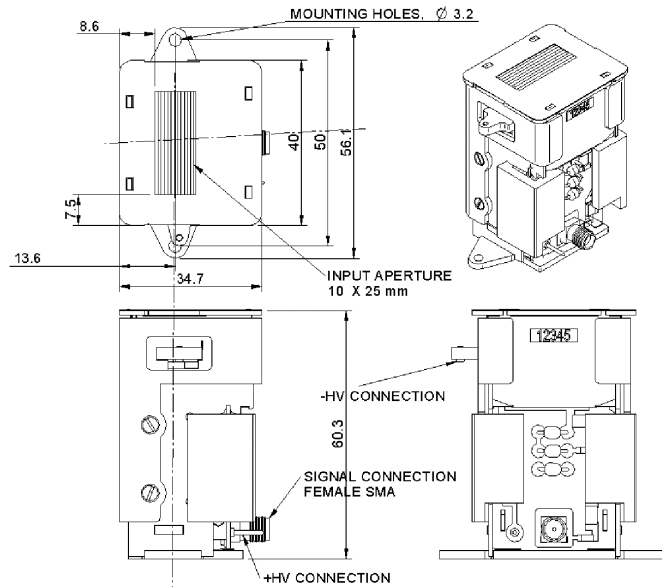

Figure 7. Shows the mechanical details for the DM291 electron multiplier.

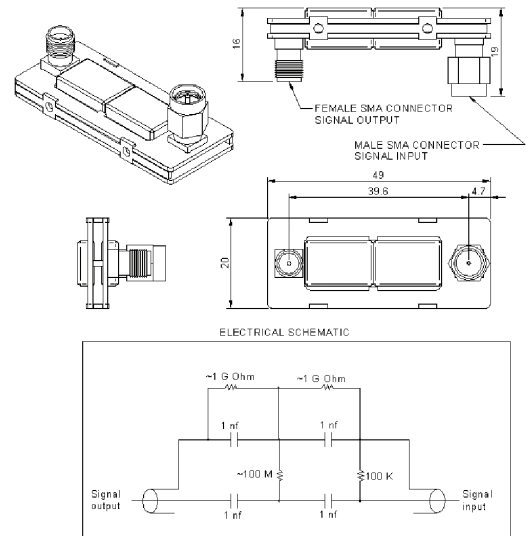

Figure 8. Shows the mechanical details for the DM345 AC signal coupler.